

TECHNICAL DATA

3 WAY AND 2 POSITION VALVE

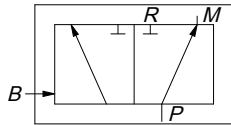
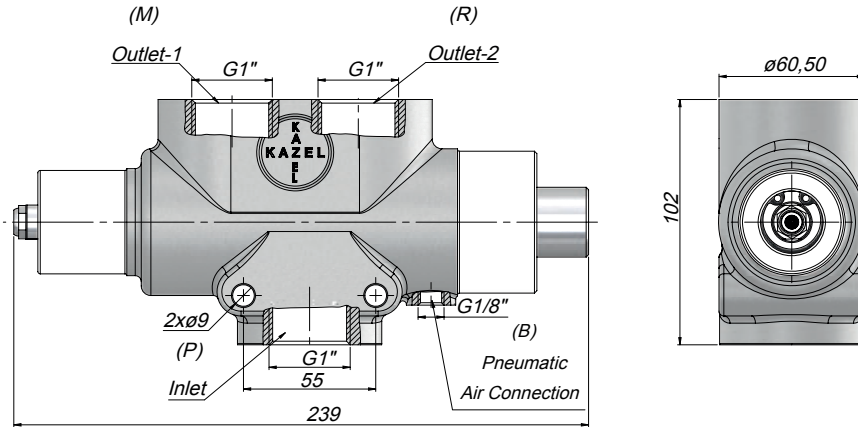

HYDRAULIC SYMBOL

| Code | Flow Rate | Max. Working Pressure | Fluid Temperature | Operating Viscosity Range | Pneumatic Working Pressure |
|-----------|-----------|-----------------------|-------------------|---------------------------|----------------------------|
| | (l/dk) | (Bar) | (°C) | (cSt) | (Bar) |
| V-SEMS-02 | 250 | 350 | -10 ~+80~ | -12-100 cSt | 7-12 |